

**AMERICAN AVK RESILIENT SEATED DUCTILE IRON GATE VALVE**  
**Tested to AWWA C509 / C515 (NRS) for Indicator Post**  
**Mechanical Joint Ends - Valve Sizes 4" - 16"**

**45/MMP**  
**MJxMJ PIV**

**Use:**

For water and neutral liquids to maximum 160°F.

**Tests:**

Hydraulic test to AWWA C509:

Shell Test: 500 PSI 4"-16"

Seat Test: 250 PSI 4"-16"

Operating Torque Test

**Optional Materials:**

Stem	4"-12" only Stainless steel AISI 430F Stainless steel AISI 304 Stainless steel AISI 316
Bonnet Bolts	4"-12" only Stainless steel AISI 304, Stainless steel AISI 316, Zinc Plated steel sealed with hot melt
Gland Bolts	4"-12" only Stainless steel AISI 316, Zinc Plated steel

**Standard Materials:**

Body, Bonnet, Post Indicator Plate, Wrench Nut	Ductile iron ASTM A536 (Wrench Nut-painted black for open left, red for open right)
Coating	Electrostatically applied fusion- bonded epoxy-resin Meets or exceeds AWWA C550
Stem	4"-12" Standard: Low Zinc Bronze ASTM B763 14"-16" Standard: Aluminum Bronze ASTM B150/B150M
Anti Friction Washers	Polyamide
Wedge	Ductile iron ASTM A536 encapsulated with EPDM-rubber compound
Wedge Nut, Thrust Collar	Bronze
Bonnet Bolts	Stainless Steel - 304 for 4"-8" sealed with hot melt Grade 8 Steel for 10"-16" sealed with hot melt
Gland Bolts	Stainless Steel - 304 Hexagon bolt
Bonnet Gasket, Wiper Ring, O-Ring Stem Seals, O-Ring Gland Seal	ASTM D2000 Buna "N" nitrile rubber

**Approvals:**

\*UL/ULC Listed  
 \*FM Approved  
 Certified to: ANSI/NSF 61, ANSI/NSF 372



\* Approved at 250 PSI working pressure, 4"-12"  
 \* Approved at 200 PSI working pressure, 14"-16"

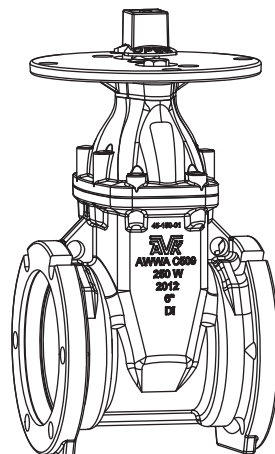

**AMERICAN AVK RESILIENT SEATED DUCTILE IRON GATE VALVE**  
**Tested to AWWA C509 / C515 (NRS) for Indicator Post**  
**Mechanical Joint Ends - Valve Sizes 4" - 16"**

**45/MMP**  
**MJxMJ PIV**

**Component List:**

- |                           |                              |                             |
|---------------------------|------------------------------|-----------------------------|
| 217. Bonnet               | 226. Wiper Ring              | 232. Lower Stem Seal O-Ring |
| 218. Bonnet Gasket        | 227. Gland Flange Bolt       | 235. Anti-Friction Washer   |
| 219. Body                 | 229. Gland O-Ring            | 236. Low Zinc NRS Stem      |
| 224. Post Indicator Plate | 230. Upper Stem Seal O-Rings | 237. Wedge                  |
| 225. Wrench Nut           | 231. Stem Seal Bushing       |                             |

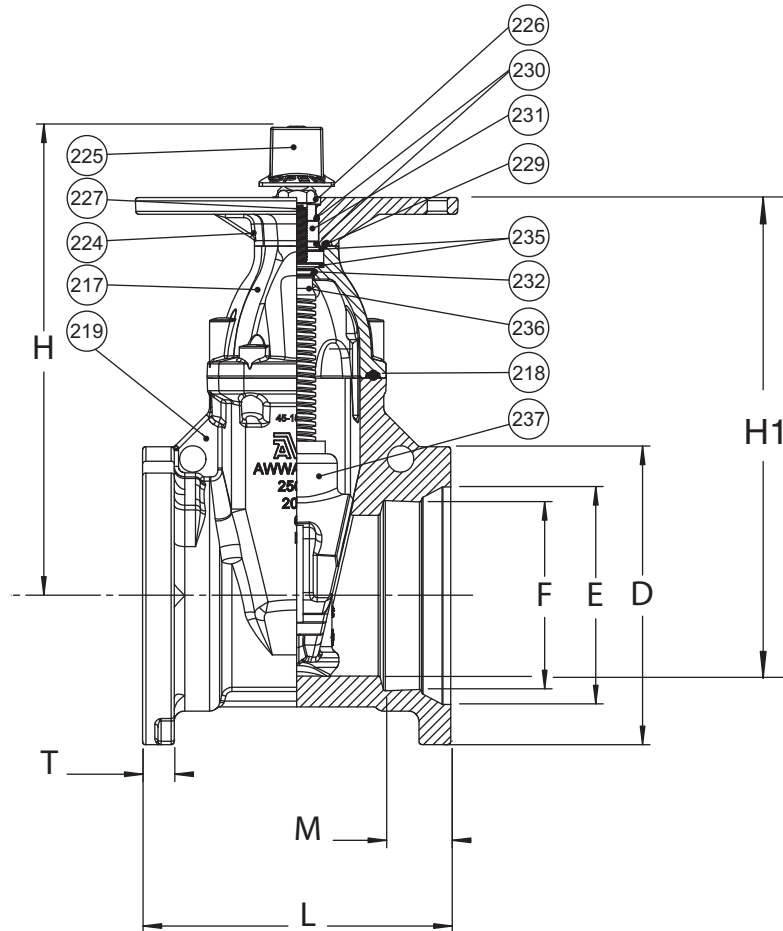

Ref No.	Size	D	E	F	H	H1	L	M	T	Turns to Open	Weight (lbs.)
45-100-MMP	4"	9.12"	6.00"	4.90"	13.50"	13.00"	10.00"	2.50"	1.00"	14	82
45-150-MMP	6"	11.12"	8.12"	7.00"	17.50"	18.00"	11.50"	2.50"	1.18"	21	123
45-200-MMP	8"	13.37"	10.27"	9.15"	21.50"	23.00"	11.50"	2.50"	1.24"	26	175
45-250-MMP	10"	15.69"	12.34"	11.20"	24.75"	27.00"	13.00"	2.50"	1.14"	32	260
45-300-MMP	12"	17.88"	14.44"	13.30"	27.63"	31.00"	14.00"	2.50"	1.22"	38	357
45-350-MMP	14"	20.31"	16.61"	15.50"	35.38"	39.00"	17.95"	3.50"	1.32"	51	814
45-400-MMP	16"	22.56"	18.64"	16.12"	35.47"	42.00"	18.00"	3.50"	1.34"	51	820

