

**AMERICAN AVK HIGH PRESSURE, 350 PSI, THREADED NOZZLE,
WET BARREL HYDRANT - Meets or exceeds AWWA C503 (latest)**

**24T/PHN
WET HIGH PRESSURE**

Use:
For water and neutral liquids to maximum 160°F.

Tests:
Hydraulic test to AWWA C503:
Shell Test: 700 PSI

Options:
Break Flange
Hydrant Check Valve (FlowGuard II ®)

Approvals:
UL Listed,
FM Approved
at 250 PSI
Certified to: ANSI/NSF 61, ANSI/NSF 372







Standard Materials:

Nozzle Section	Ductile iron ASTM A536
Caps, Dummy Nuts	Cast iron ASTM A126 class B
Stems, Nozzles, Stem Nuts	Bronze
Valve Discs	Bronze encapsulated with Nitrile Rubber
O-rings,	NBR
Cap Gaskets	Neoprene rubber
Nozzle Retainer Screws Thrust Collars, Thrust Nuts	Stainless Steel
Cap Chains	Zinc Plated Steel
Coating	Electrostatically applied fusion-bonded epoxy-resin

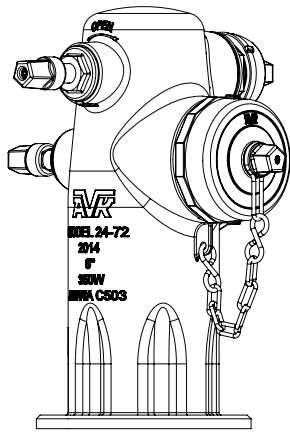
Note: Nozzles, Stem Nuts and Stem Seals field replaceable
Pumper Nozzles interchangeable from 4" to 4½"



Series 2472-Phn
1 Pumper, 1 Hose Outlet



Component List:

- | | | |
|--|-------------------------------|-----------------------------|
| 19. Hose Nozzle Cap | 112. Dummy Nut | 136. 2.5" Thrust Collar |
| 22. Hose Nozzle O-Ring | 113. Dummy Nut Retaining Bolt | 137. 4.5" Valve Disc |
| 23. Nozzle Retaining Screw (not shown) | 114. Stem Nut Retaining Screw | 138. 4.5" Valve Stem |
| 24. Chain Set | 115. Hose Nozzle Cap Gasket | 139. 4.5" Thrust Nut |
| 25. Pumper Nozzle O-Ring | 116. Hose Nozzle | 140. 4.5" Thrust Collar |
| 28. Pumper Cap | 120. Pumper Cap Gasket | 141. 4.5" Thrust Nut O-ring |
| 101. Nozzle Section | 126. Pumper Nozzle | 142. 2.5" Thrust Nut O-ring |
| 109. Outer Stem Nut O-ring | 133. 2.5" Valve Disc | |
| 110. Stem Nut | 134. 2.5" Valve Stem | |
| 111. Inner Stem Nut O-Ring | 135. 2.5" Thrust Nut | |

Top may be tapped for 2.5" auxiliary valve

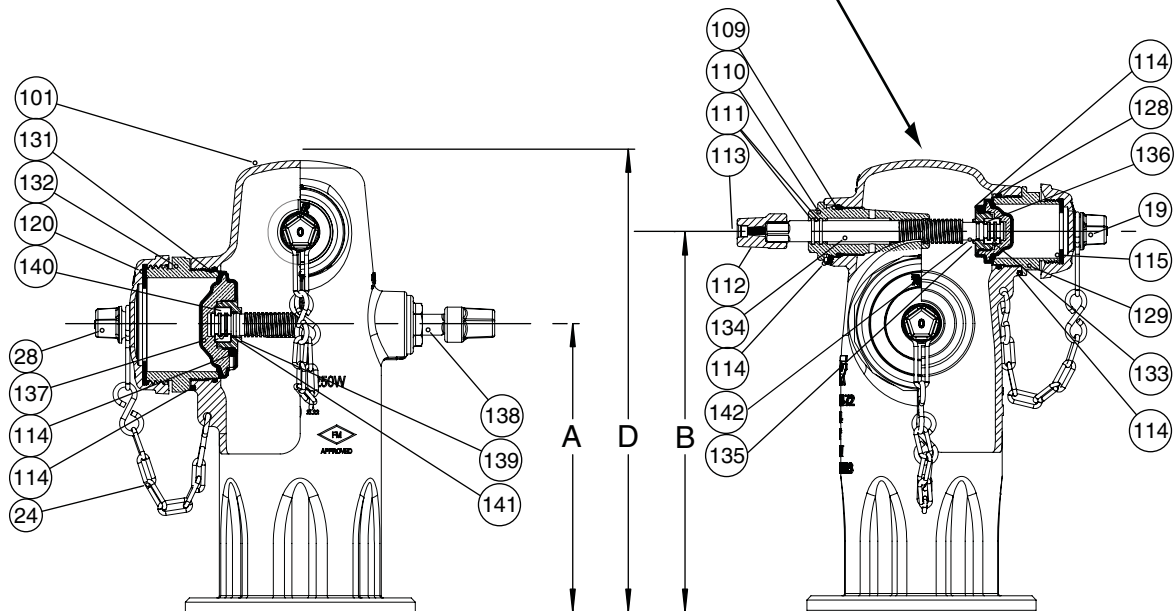

Ref No.	Outlets	A	B	D	Weights (lbs)
24T-PHN	1x2.5", 1x4.5"	14"	18.50"	22.50"	82

With optional factory assembled breakable unit, add 42 lbs. to shipping weight.

