

Component List:

- 30. Mounting Bolt
- 31. Mounting Washers
- 34. Mounting Nut
- 124. Wet Barrel Hydrant Break Ring
- 128. Body
- 129. Upper Retainer Cage
- 130. Lower Seat Ring
- 132. FlowGuard II ® Ball

Component List:

- 143. Upper O-ring
- 144. Seat Ring O-ring
- 145. Lower O-ring
- 146. Adapter Plate *
- 147. Adapter Plate Gasket *

* Not required for use with AVK Wet Barrel Hydrants

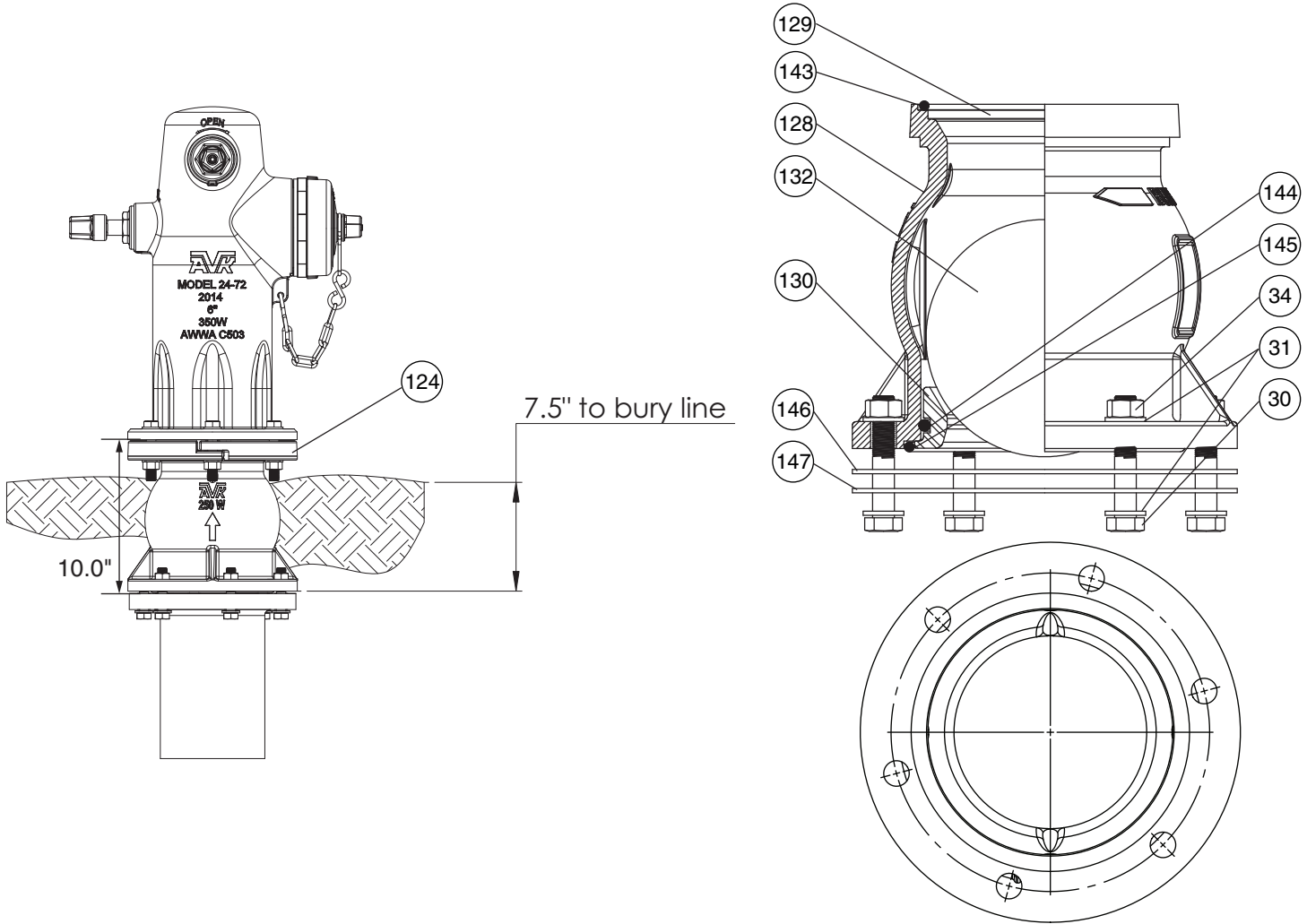

Ref. No.	Description	Pitch Diameter	Hole Diameter	Number of Holes	Weight Lbs.
24-150-88-90	AWWA C503	9.37"	0.75"	6	90
24-150-88-92	Ansi B16.1 class 125	9.49"	0.87"	8	90
24-150-88-93	San Diego	9.49"	0.87"	6	90

