

# AMERICAN AVK STAINLESS STEEL, UL LISTED, WET BARREL HYDRANT

Meets or exceeds AWWA C503 (latest) - Working Pressure - 200 PSI

**24S/PHN/PHH  
WET STAINLESS**

### Use:

For water and neutral liquids to maximum 160°F.

### Tests:

Hydraulic test to AWWA C503:  
Shell Test: 400 PSI

### Options:

Break Flange  
Hydrant Check Valve (FlowGuard II ® )  
Storz Nozzles, 2½" through 5"  
6, or 8 bolt flange mounting patterns.

### Approvals: UL Listed,



\* Storz aluminum cap, UL, Storz iron cap, non - UL

### Standard Materials:

Nozzle Section	Cast 304 stainless steel CF-8 ASTM A351
Caps, Dummy Nuts	Cast iron ASTM A126 class B
Stems, Nozzles, Stem Nuts	Bronze
Valve Discs	Bronze encapsulated with Nitrile Rubber
O-rings,	NBR
Cap Gaskets	Neoprene rubber
Nozzle Retainer Screws Thrust Collars, Thrust Nuts	Stainless Steel
Cap Chains	Zinc Plated Steel
Coating	Electrostatically applied fusion-bonded epoxy- resin

Note: Nozzles, Stem Nuts and Stem Seals field replaceable

Pumper Nozzles interchangeable from 4" to 5"

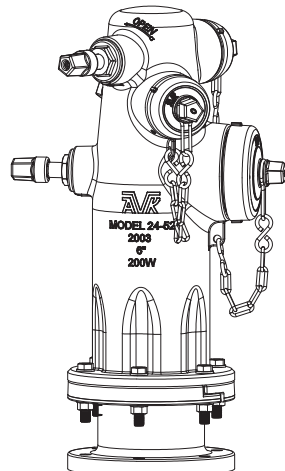

Series 245X-PHH  
2 Pumper, 1 Hose Outlet \*

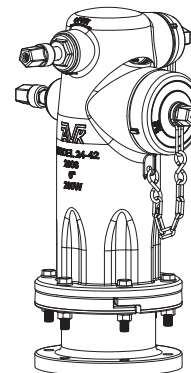

Series 244X-PHN  
1 Pumper, 1 Hose Outlet \*



\* Shown with optional Breakable Flange Assemblies  
Note: All configurations supplied with 6 - 3/4" holes at 9 3/8" pitch diameter.  
Breakable Flange Assemblies with 6" ANSI Standard 8 hole configuration are available as an option.

# AMERICAN AVK STAINLESS STEEL, UL LISTED, WET BARREL HYDRANT

**24S/PHN/PHH  
WET STAINLESS**

Meets or exceeds AWWA C503 (latest) - Working Pressure - 200 PSI

## Component List:

- |  |                               |                                |
|--|-------------------------------|--------------------------------|
| 19. Hose Nozzle Cap                    | 112. Dummy Nut                | 127. Wet Barrel Flange Section |
| 22. Hose Nozzle O-Ring                 | 113. Dummy Nut Retaining Bolt | 133. 2.5" Valve Disc           |
| 23. Nozzle Retaining Screw (not shown) | 114. Stem Nut Retaining Screw | 134. 2.5" Valve Stem           |
| 24. Chain Set                          | 115. Hose Nozzle Cap Gasket   | 135. 2.5" Thrust Nut           |
| 25. Pumper Nozzle O-Ring               | 116. Hose Nozzle              | 136. 2.5" Thrust Collar        |
| 28. Pumper Cap                         | 120. Pumper Cap Gasket        | 137. 4.5" Valve Disc           |
| 31. Nozzle Section Washer              | 122. Nozzle Section Bolt      | 138. 4.5" Valve Stem           |
| 101. Nozzle Section                    | 123. Wet Barrel Flange O-Ring | 139. 4.5" Thrust Nut           |
| 109. Outer Stem Nut O-ring             | 124. Break Ring               | 140. 4.5" Thrust Collar        |
| 110. Stem Nut                          | 125. Nozzle Section Nut       | 141. 4.5" Thrust Nut O-ring    |
| 111. Inner Stem Nut O-Ring             | 126. Pumper Nozzle            | 142. 2.5" Thrust Nut O-ring    |

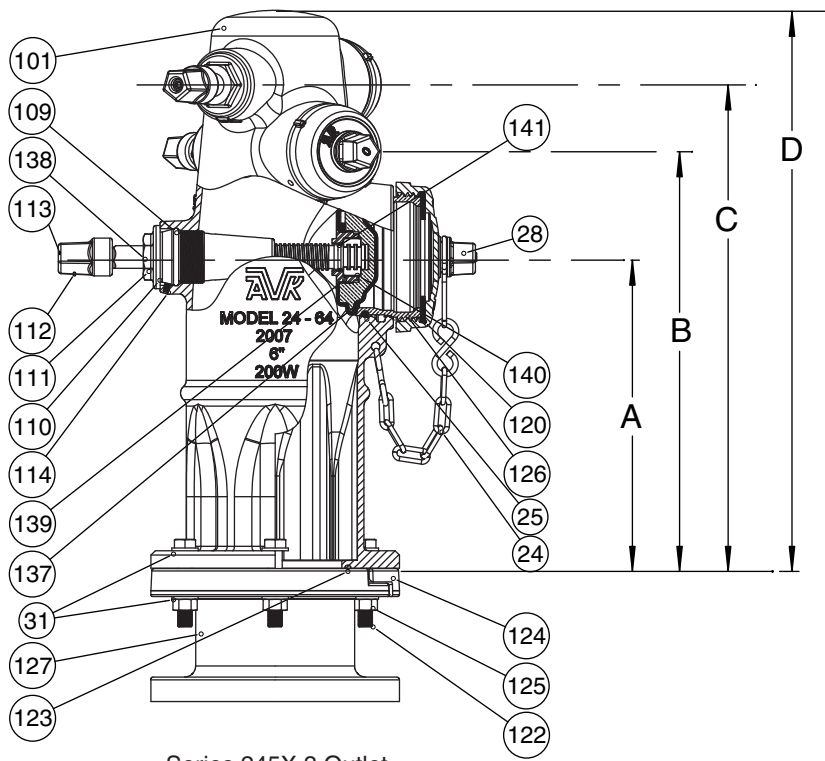

Series 245X 3 Outlet

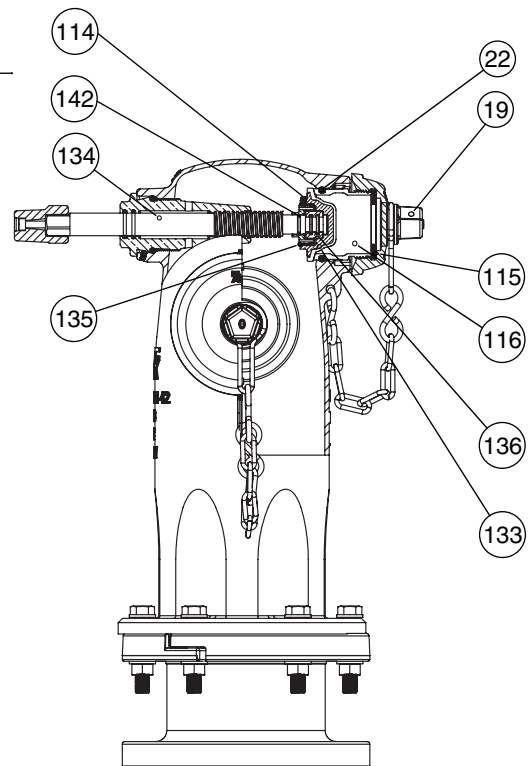

Series 244X 2 Outlet

Ref No.	Outlets	A	B	C	D	Weights (lbs)
24S-PHN	1x2.5", 1x4"/4.5"	14"	18.75"	-	21.50"	101
24S-PHH	2x2.5", 1x4"/4.5"	14"	18.75"	21.75"	25.00"	101

With optional factory assembled breakable unit, add 42 lbs. to shipping weight.

Note: 2442-PHN, 2452-PHH configurations supplied with 6 - 3/4" holes at 9 3/8" pitch diameter, to AWWA C503 specifications.

2443-PHN, 2453-PHH configurations supplied with 6 - 7/8" holes at 9 1/2" pitch diameter, to San Diego specifications.

2444-PHN, 2454-PHH configurations supplied with 8 - 7/8" holes at 9 1/2" pitch diameter, to ANSI B16.1-1975 class 125 specifications.

Breakable Flange Assemblies are available with the above bolting options.

