

**AMERICAN AVK Company FlowGuard II®
Water Loss and Cross Contamination Reduction Valve
For all American AVK Wetbarrel Hydrants**

**24/88X
FlowGuard II**

Use:

For water and neutral liquids to maximum 160°F.

Optional Materials:

Mounting Hardware Stainless Steel

Standard Materials:

Body	Ductile iron ASTM A536
Coating	Electrostatically applied fusion-bonded epoxy-resin Meets or exceeds AWWA C550
Retaining Cage, Seat Ring	Standard: Stainless Steel, ASTM A582
Ball	Ductile iron ASTM A536 encapsulated with EPDM-rubber compound
Mounting Hardware	Stainless Steel - 304
O-rings	ASTM D2000 Buna "N" nitrile rubber

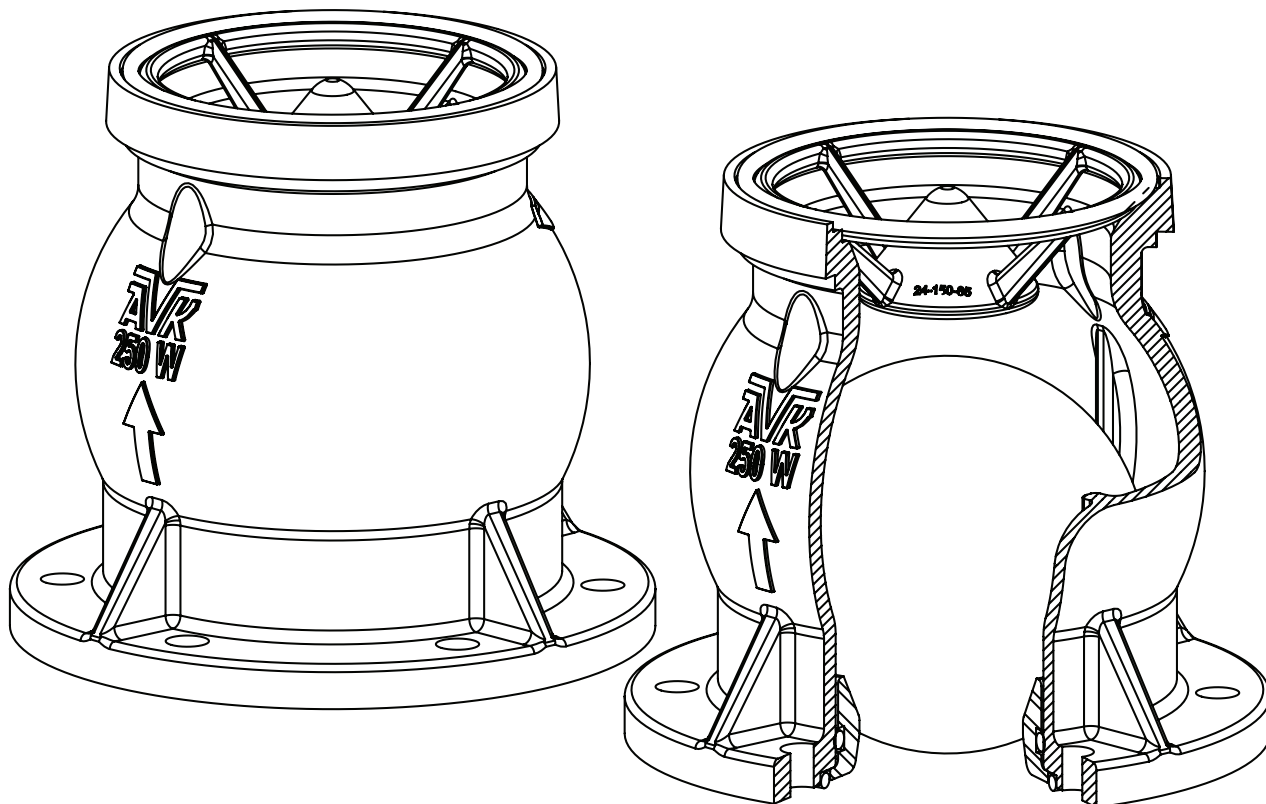

Component List:

- 30. Mounting Bolt
- 31. Mounting Washers
- 34. Mounting Nut
- 124. Wet Barrel Hydrant Break Ring
- 128. Body
- 129. Upper Retainer Cage
- 130. Lower Seat Ring
- 132. FlowGuard II ® Ball
- 143. Upper O-ring
- 144. Seat Ring O-ring
- 145. Lower O-ring

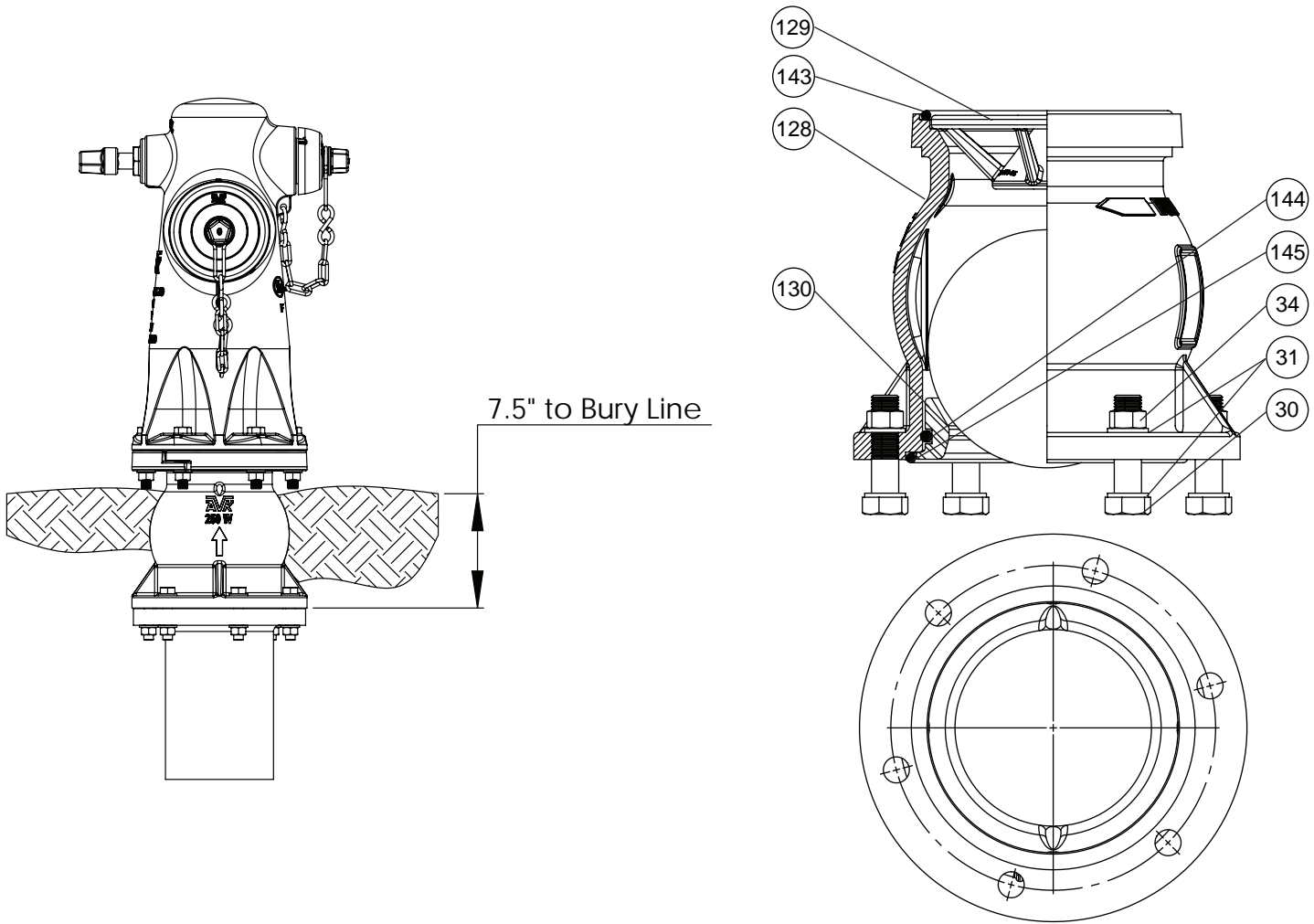

Ref. No.	Description	Pitch Diameter	Hole Diameter	Number of Holes	Weight Lbs.
24-150-88-90	AWWA C503	9.37"	0.75"	6	90
24-150-88-92	Ansi B16.1 class 125	9.49"	0.87"	8	90
24-150-88-93	San Diego	9.49"	0.87"	6	90

